

# 800MHz Digital Pico Repeater

## MP-0832

### Features

- Bandwidth adjustable for both downlink and uplink.
- Support Cellular Communication and NB-IoT (Stand Alone, Guard Band and In-band).
- Max. 2 pass band segments with independent ON/OFF for maximum flexibility.
- Max. 20dBm total output power.
- Offline isolation detection for easy commissioning.
- Low noise amplifier improves system noise figure for better voice quality and reduced drop call.
- Highly integrated design with miniaturized enclosure, small size, light weight and easy to install.
- Includes Modem for remote monitoring (option).
- Compatible to Comba generic OMT and CMS platform.



### Block Diagram

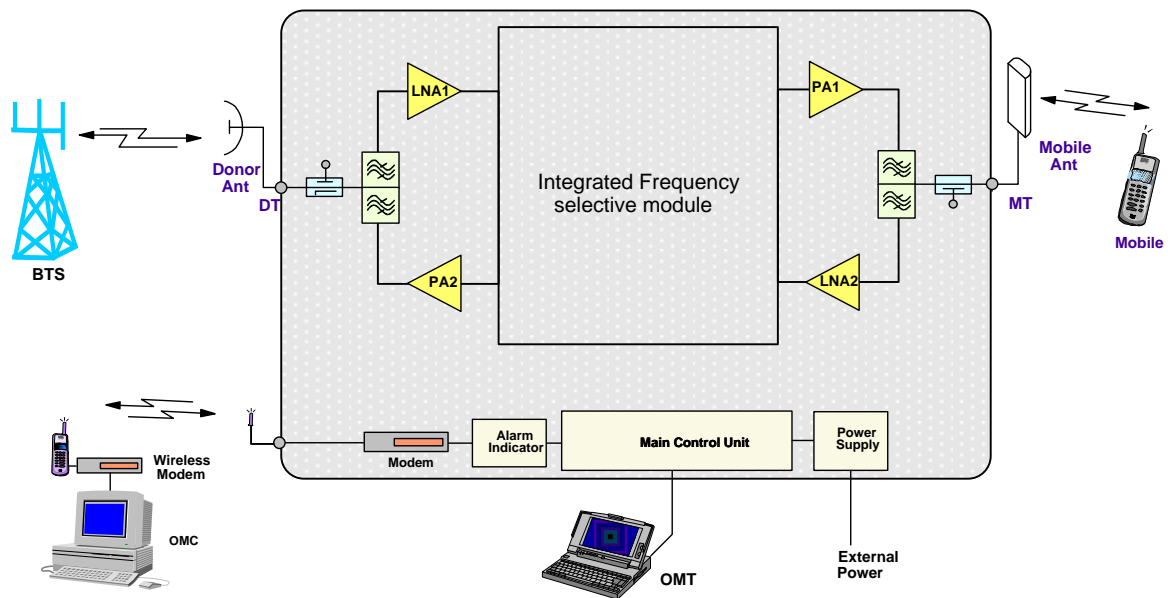

## Specifications

Electrical		20dBm
Operating Frequency, Uplink	MHz	832-862
Operation Frequency, Downlink	MHz	791-821
Operating Bandwidth Per Sub-band	MHz	5 / 10 / 15 / 20 adjustable
Number of Sub-bands		2
Total Output Power, Uplink	dBm	17
Total Output Power, Downlink	dBm	20
Maximum System Gain	dB	75
Attenuation Adjustment Range (1dB step)	dB	0-30
ALC Range	dB	≥ 15
Pass Band Ripple at FBW, p-p	dB	≤ 4
Uplink Noise Figure	dB	≤ 7
System Group Delay	μsec	≤ 6
Spurious Emission Mask		Compliance with 3GPP TS 36.106
Intermodulation		
EVM		
Absolute Maximum RF input power	dBm	
Input VSWR		≤ 2.0
Impedance	Ω	50
Mechanical		
Dimensions, W x H x D	mm	198 x 78 x 43
Weight (approx.)	kg	0.5
External Power Supply Unit	Input	VAC
	Output	VDC
Power Consumption	W	14
Enclosure Cooling		Convection
Connectors		SMA-Female (SMA-Male to N-Female jumper included)
Operating Temperature	°C	-10 to +40
Operating Humidity		≤ 85%
Environmental Class		IP30
MTBF	hr	≥ 50,000
Remote Monitoring (option)		Built in Wireless Modem

Note: Typical specification at room temperature